

Proportional directional valves, pilot operated, with electrical position feedback and integrated electronics (OBE)

RE 29075/08.13
Replaces: 08.04

1/22

Type 4WRKE

Size 10 to 35
Component series 3X
Maximum operating pressure 350 bar
Maximum flow 3,000 l/min

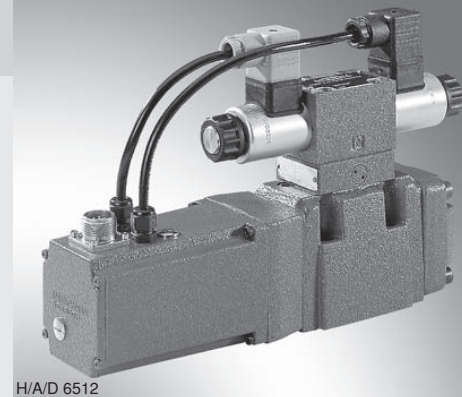

Table of contents

Contents	Page
Features	1
Ordering code	2
Symbols	3
Function, section, valve particularities	4, 5
Technical data	6, 7
Block diagram of the integrated electronics (OBE)	8
Characteristic curves	9 ... 14
Dimensions	15 ... 20
Accessories	21

Features

- Pilot operated 2-stage proportional directional valve with electrical position feedback of the main control spool and integrated electronics (OBE)
- Control of flow direction and size of a flow
- Operation by means of proportional solenoids
- Subplate mounting:
Porting pattern according to ISO 4401
- Electrical position feedback
- Spring-centered main control spool
- Pilot control valve:
Single-stage proportional directional valve
- Main stage with position control

Symbols

Simplified

Example:

Pilot oil supply external

Pilot oil drain external

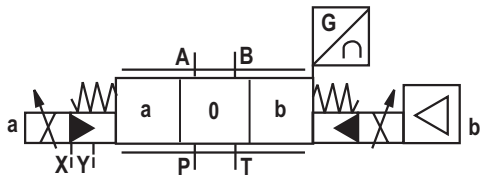

Detailed

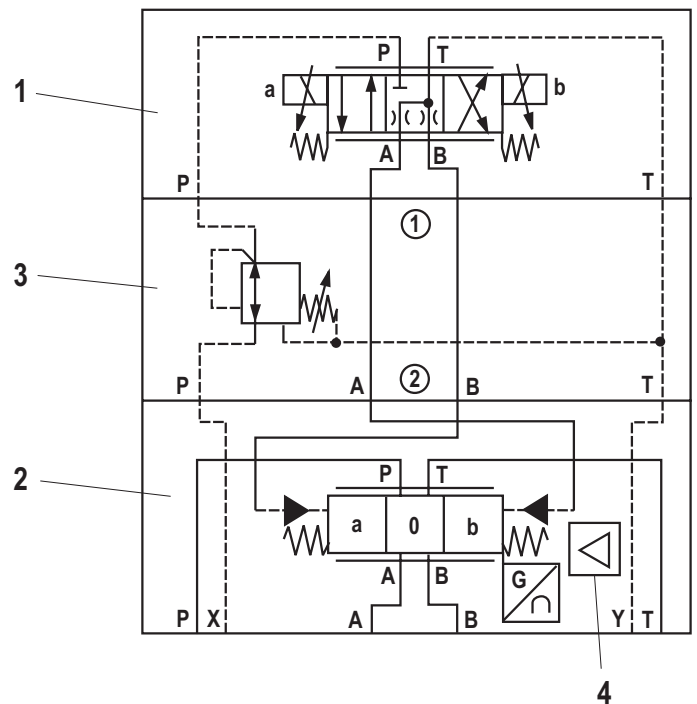

Example:

- 1 Pilot control valve type 4WRAP 6...
- 2 Main valve
- 3 Pressure reducing valve
type ZDR 6 DP0-4X/40YM-W80
- 4 Integrated electronics (OBE)

Function, section

Pilot control valve type 4WRAP 6 W7.3X/G24... (1st stage)

The pilot control valve is a direct operated proportional valve. The control edge dimensions have been optimized for use as a pilot control valve for proportional directional valves type 4WRKE.

The proportional solenoids are pressure-tight, wet-pin AC solenoids with detachable coils. They transfer electric current proportionally into mechanical force. An increase of the current strength results in a correspondingly higher magnetic force. The set magnetic force remains the same during the total control stroke.

The pilot control valve mainly consists of the housing (1), the proportional solenoid (2 and 3), the valve control spool (4) and springs (5 and 6).

In a non-actuated state both actuators are connected to the tank. If one of the two solenoids (2 or 3) is excited, the magnetic force will move the valve control spool (4) towards the spring (5 or 6).

After having overcome the overlap area, the connection of one of the two actuators is blocked and the connection to the pressroom is made. There is a flow from P to the control chamber of the main stage.

Type 4WRAP 6 W7.3X/G24...

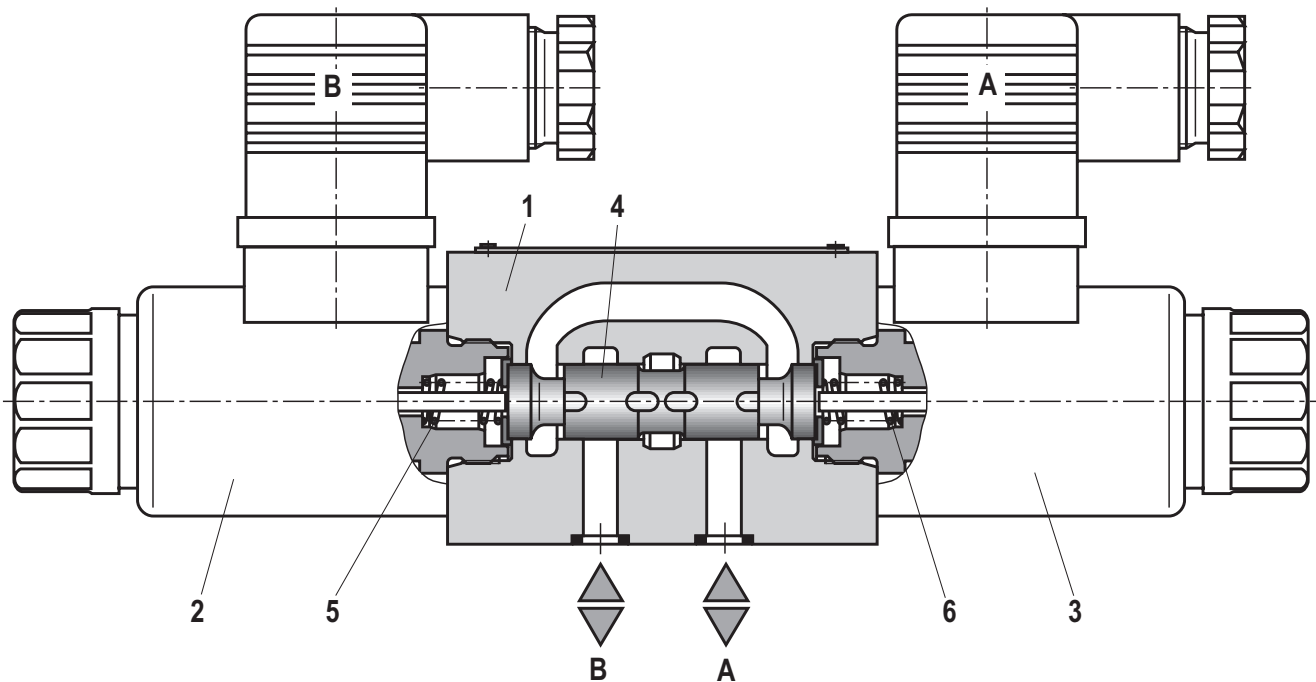

Function, section, valve particularities

Valves of type 4WRKE are 2-stage proportional directional valves. They control the of flow direction and size.

The main stage is position-controlled so that the control spool position is independent from flow forces also in the case of bigger flows.

The valves mainly consist of the pilot control valve (1), the housing (8), the main control spool (7), the covers (5 and 6), the centering spring (4), the inductive position transducer (9) and the pressure reducing valve (3).

If there is no input signal, the main control spool (7) will be kept in the central position by the centering spring (4). Both control chambers in the covers (5 and 6) are connected to the tank via the valve control spool (2).

The main control spool (7) is connected to suitable control electronics via the inductive position transducer (9). Both the change of position of the main control spool (7) and the change of the command value at the junction summing of the amplifier create a differential voltage.

During the comparison of command and actual value a possible control deviation is determined via the electronics and

the proportional solenoid of the pilot control valve (1) is supplied with current.

The current induces a force in the solenoid which operates the control spool via a plunger in a row. The flow which has been released via the control cross sections causes an adjustment of the main control spool.

The main control spool (7) with the core of the inductive position transducer (9) attached to it is displaced until the actual value corresponds to the command value. In a controlled state the main control spool (7) is balanced and kept in this control position.

The control spool stroke and the control opening change proportionally to the command value.

The control electronics are integrated in the valve. By adjusting valve and electronics, the deviation in series production of the devices is kept low.

The tank lines must not be allowed to run empty; a preload valve is to be installed in the case of a corresponding installation condition (counterbalance pressure approx. 2 bar).

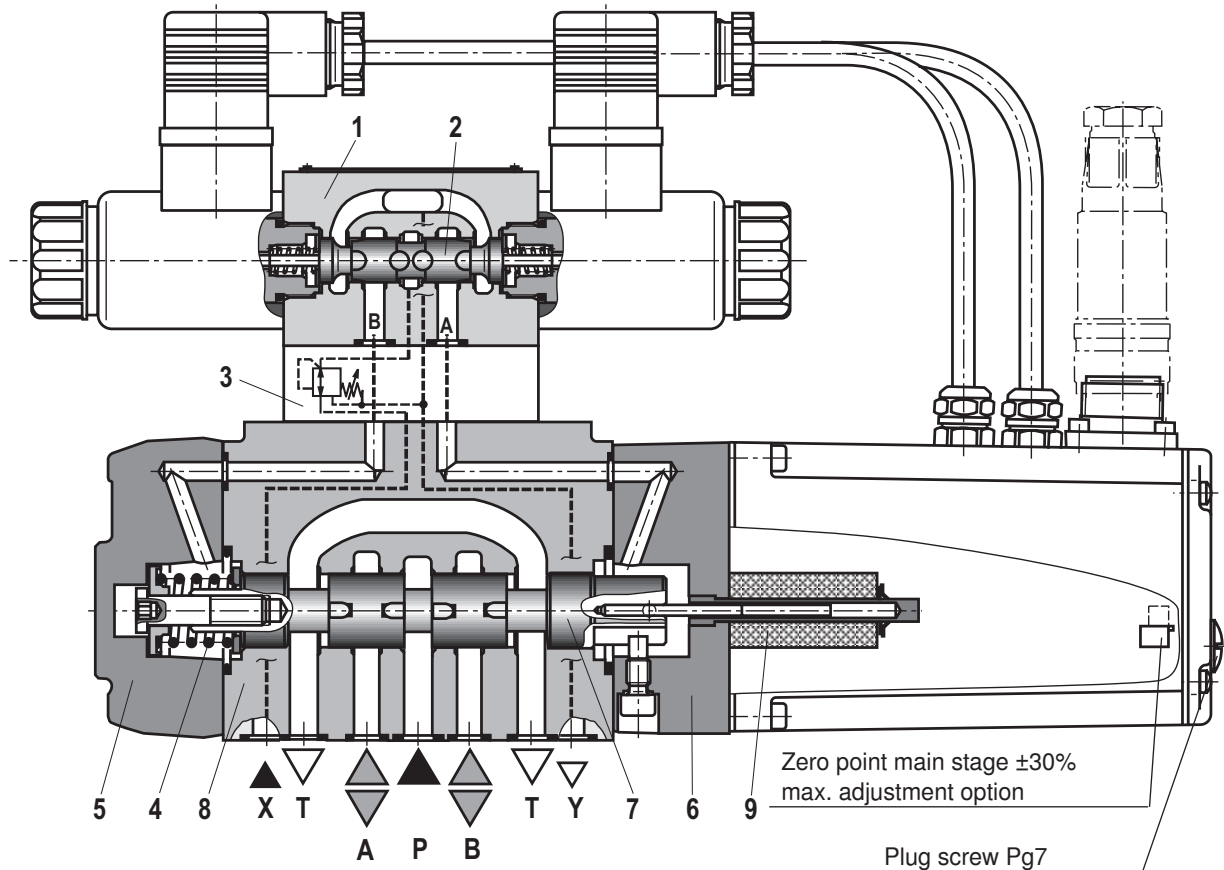

Valve particularities

- The 2nd stage is mainly built up from components of our proportional valves.
- The zero point adjustment at "**zero point main stage**" is made at the factory and can be adjusted in a range of $\pm 30\%$ of the nominal stroke via a potentiometer in the control electronics. Access in the integrated control electronics by removing a plug screw on the front side of the cover housing.

- When the pilot control valve or the control electronics are exchanged, they are to be re-adjusted. All adjustments may be implemented by instructed experts only.

Notice!

Changes in the zero point may result in damage to the system and may only be implemented by instructed specialists!

Technical data (for applications outside these parameters, please consult us!)

general							
Sizes	Size	10	16	25	27	32	35
Installation position and commissioning information		Preferably horizontal, see RE 07800					
Storage temperature range	°C	-20 to +80					
Ambient temperature range	°C	-20 to +50					
Weight	kg	8.7	11.2	16.8	17	31.5	34
Sine test according to DIN EN 60068-2-6:2008 ¹⁾		10 cycles, 10...2,000..10 Hz with logarithmic frequency changing speed of 1 oct./min, 5 to 57 Hz, amplitude 1.5 mm (p-p), 57 to 2,000 Hz, amplitude 10 g, 3 axes					
Random test according to DIN EN 60068-2-64:2009 ¹⁾		20...2,000 Hz, amplitude 0.05 g ² /Hz (10 g _{RMS}) 3 axes, testing time 30 min per axis					
Shock test according to DIN EN 60068-2-27:2010 ¹⁾		Half sine 15 g / 11 ms, 3 times in positive and 3 times in negative direction per axis, 3 axes					
Humid heat, cyclic according to DIN EN 60068-2-30:2006		Variant 2 +25 °C to +55 °C, 90% to 97% relative humidity, 2 cycles with 24 hours each					

¹⁾ The information on mechanical load applies to the fastening level of the integrated valve electronics.

hydraulic (measured at $p = 100$ bar with HLP46 at $40 \text{ °C} \pm 5 \text{ °C}$)

Operating pressure	Pilot control valve Pilot oil supply	bar	25 to 315						
	Main valve, connection P, A, B	bar	Up to 315	Up to 350	Up to 350	Up to 210	Up to 350	Up to 350	
Return flow pressure	Connection T	Pilot oil drain, internal	bar	Static < 10 (pilot control valve)					
		Pilot oil drain, external	bar	Up to 315	Up to 250	Up to 250	Up to 210	Up to 250	Up to 250
	Connection Y	bar	Static < 10 (pilot control valve)						
Rated flow $q_{Vnom} \pm 10\%$ with $\Delta p = 10$ bar Δp = valve pressure differential		l/min	-	125	-	-	-	-	
			25	150	-	-	-	-	
			50	200	220	-	400	-	
			100	220	350	500	600	1000	
Recommended maximum flow		l/min	170	460	870	1000	1600	3000	
Pilot oil flow at port X and/or Y with stepped input signal from 0 to 100% (315 bar)		l/min	4.1	8.5	11.7	11.7	13.0	13.0	
Hydraulic fluid			See table page 7						
Maximum admissible degree of contamination of the hydraulic fluid - cleanliness class according to ISO 4406 (c)			Pilot control valve: Class 17/15/12 ¹⁾ Main stage: Class 20/18/15 ¹⁾						
Hydraulic fluid temperature range	°C		-20 to +80, preferably +40 to +50						
Viscosity range	mm ² /s		20 to 380, preferably 30 to 45						
Hysteresis	%		≤ 1						
Response sensitivity	%		≤ 0.5						

¹⁾ The cleanliness classes stated for the components need to be maintained in hydraulic systems. Effective filtration prevents faults and simultaneously increases the life cycle of the components.

For the selection of the filters see
www.boschrexroth.com/filter

Technical data (for applications outside these parameters, please consult us!))

Hydraulic fluid	Classification	Suitable sealing materials	Standards
Mineral oils and related hydrocarbons	HL, HLP	NBR, FKM	DIN 51524
Flame-resistant – containing water	HFC (Fuchs HYDROTHERM 46M, Petrofer Ultra Safe 620)	NBR	ISO 12922
Phosphoric acid ester	HFD-R	FKM	

 **Important information on hydraulic fluids!**

- For more information and data on the use of other hydraulic fluids refer to data sheet 90220 or contact us!
- There may be limitations regarding the technical valve data (temperature, pressure range, life cycle, maintenance intervals, etc.)!
- The flash point of the process and operating medium used must be 40 K greater than the maximum solenoid surface temperature.

- **Flame-resistant – containing water:** Maximum pressure differential per control edge 175 bar. Pressure pre-loading at the tank port > 20% of the pressure differential; otherwise, increased cavitation.
- Life cycle as compared to operation with mineral oil HL, HLP 50% to 100%

electrical

Voltage type	Direct voltage
Signal type	Analog
Maximum power	W 72 (average = 24 W)
Electrical connection	Mating connector according to DIN EN 175201-804
Protection class of the valve according to EN 60529	IP65 with mating connector mounted and locked
Control electronics	Integrated in the valve, see page 8

Connector pin assignment	Contact	Signal with A1	Signal with F1	Signal with A5
Supply voltage	A	24 VDC (18 to 35 VDC); $I_{max} = 1.5$ A; impulse load ≤ 3 A		
	B	0 V		
Reference (actual value)	C	Reference potential for actual value (contact "F")	Enable 4 to 24 V	
Differential amplifier input (Command value)	D	± 10 V	4 to 20 mA	± 10 V
	E	0 V reference potential to pin D		0 V reference potential for pin D and F
Measuring output (actual value)	F	± 10 V	4 to 20 mA	± 10 V
	PE	Connected to cooling element and valve housing		

Command value: Reference potential at E and positive command value at D result in flow from P → A and B → T.
Reference potential at E and negative command value at D result in flow from P → B and A → T.

Connection cable: Recommendation: – Up to 25 m line length: Type LiYCY 7 x 0.75 mm²
– Up to 50 m line length: Type LiYCY 7 x 1.0 mm²
Only connect the shield to PE on the supply side.

Notice: **Electric signals taken out via valve electronics (e.g. actual value) must not be used for switching off safety-relevant machine functions!**

Block diagram of the integrated electronics (OBE)

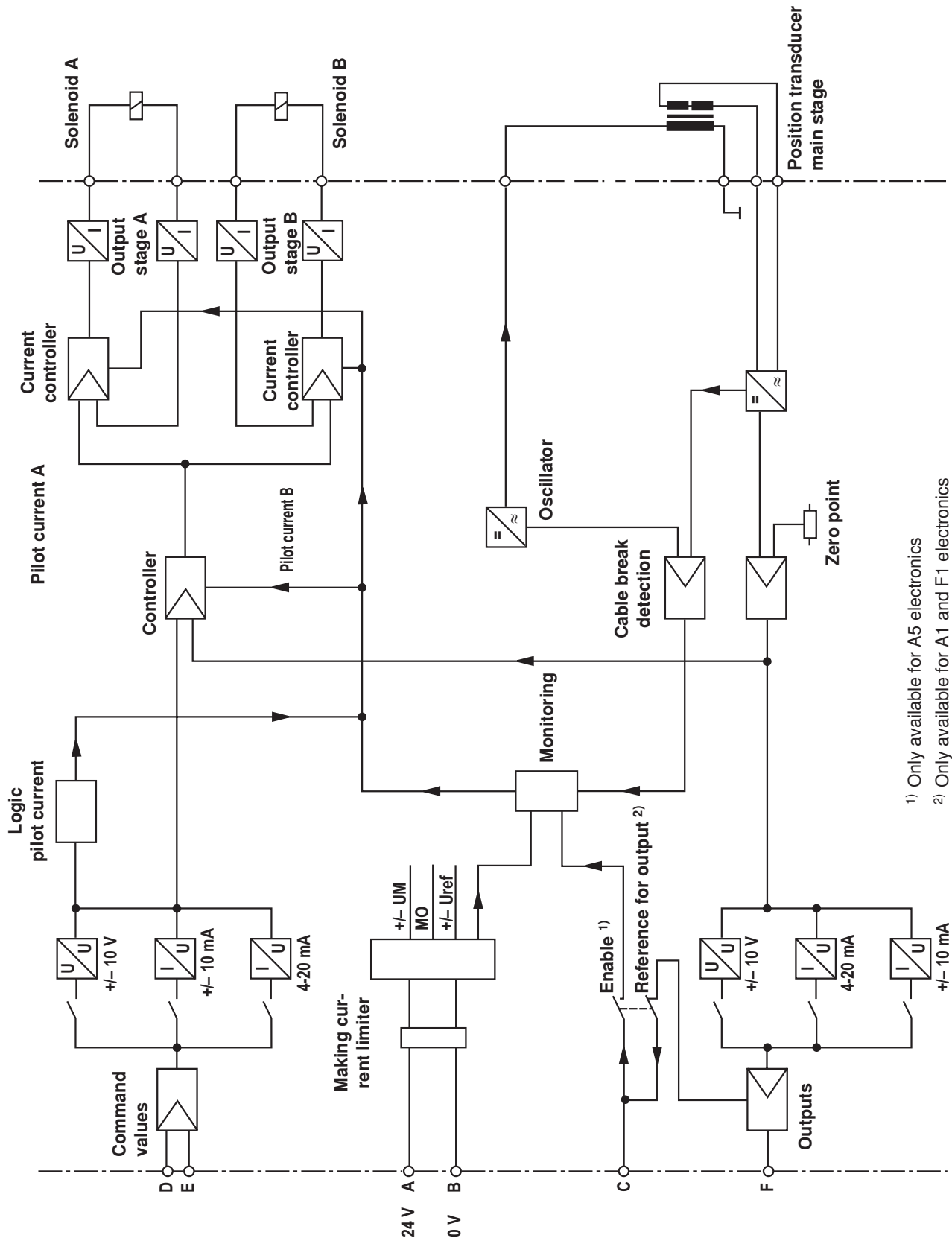

1) Only available for A5 electronics

2) Only available for A1 and F1 electronics

Characteristic curves (measured with HLP46, $\vartheta_{oil} = 40 \text{ °C} \pm 5 \text{ °C}$)

Flow command value function with e.g.
P → A / B → T 10 bar valve pressure differential or
P → A or A → T 5 bar per control edge

Control spool E, W, and R

Control spool with characteristic curve L

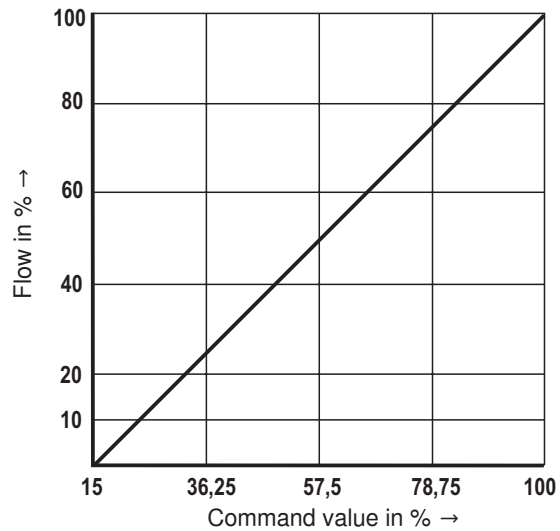

Control spool with characteristic curve P

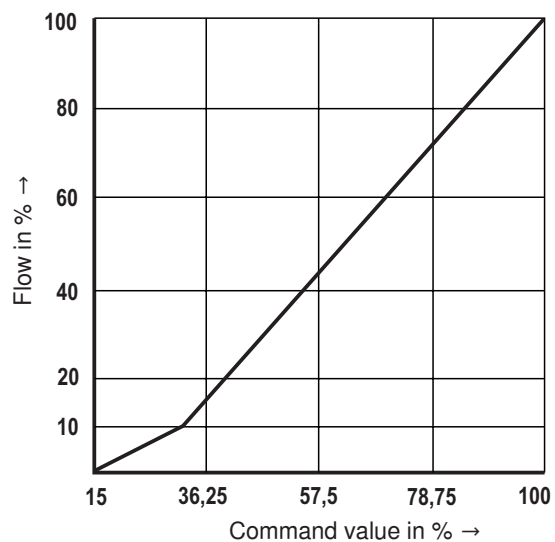

Characteristic curves: Size 10 (measured with HLP46, $\vartheta_{oil} = 40 \text{ }^\circ\text{C} \pm 5 \text{ }^\circ\text{C}$)

Transition function with stepped electric input signals

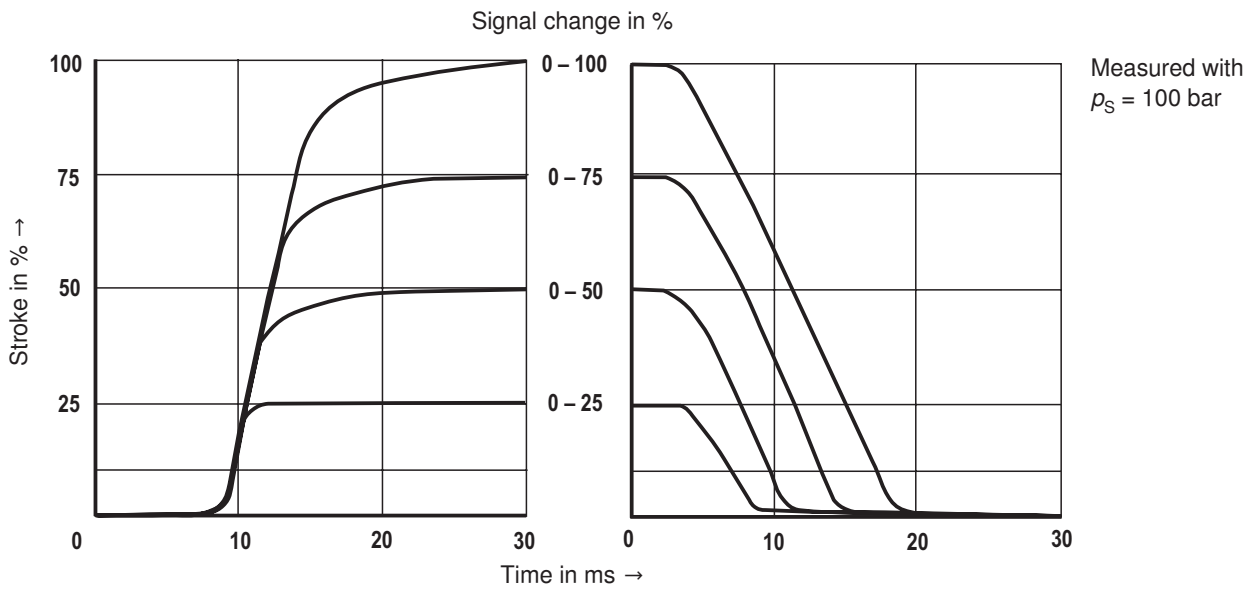

Flow/load function with maximum valve opening
(tolerance $\pm 10\%$)

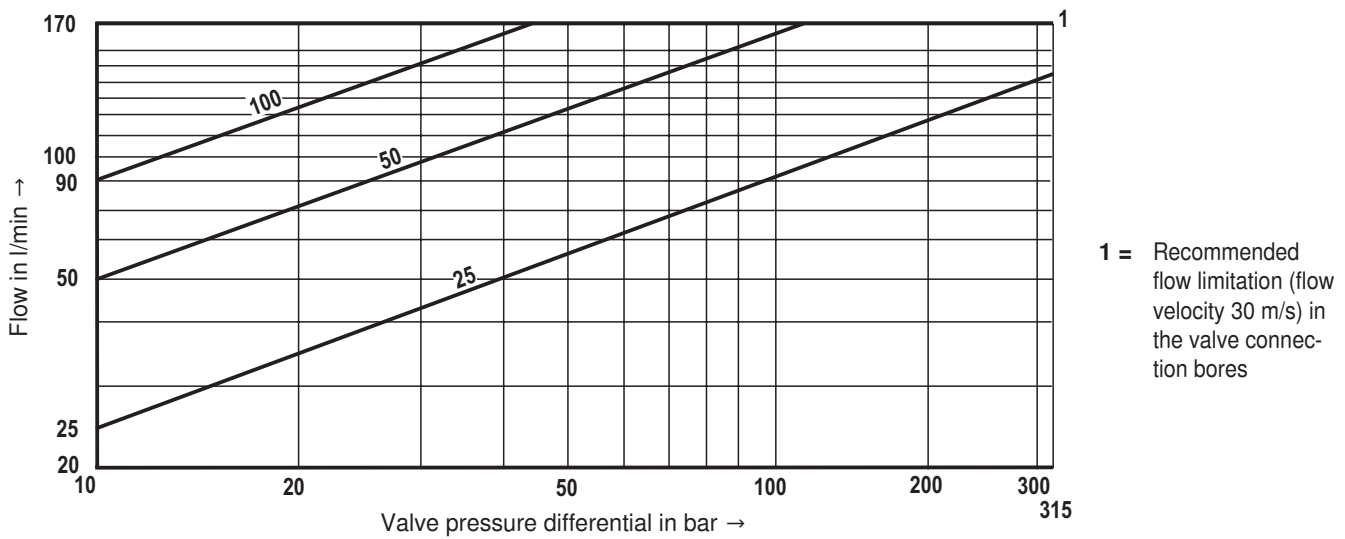

Characteristic curves: Size 16 (measured with HLP46, $\vartheta_{oil} = 40 \text{ }^\circ\text{C} \pm 5 \text{ }^\circ\text{C}$)

Transition function with stepped electric input signals

Measured with $p_s = 100 \text{ bar}$

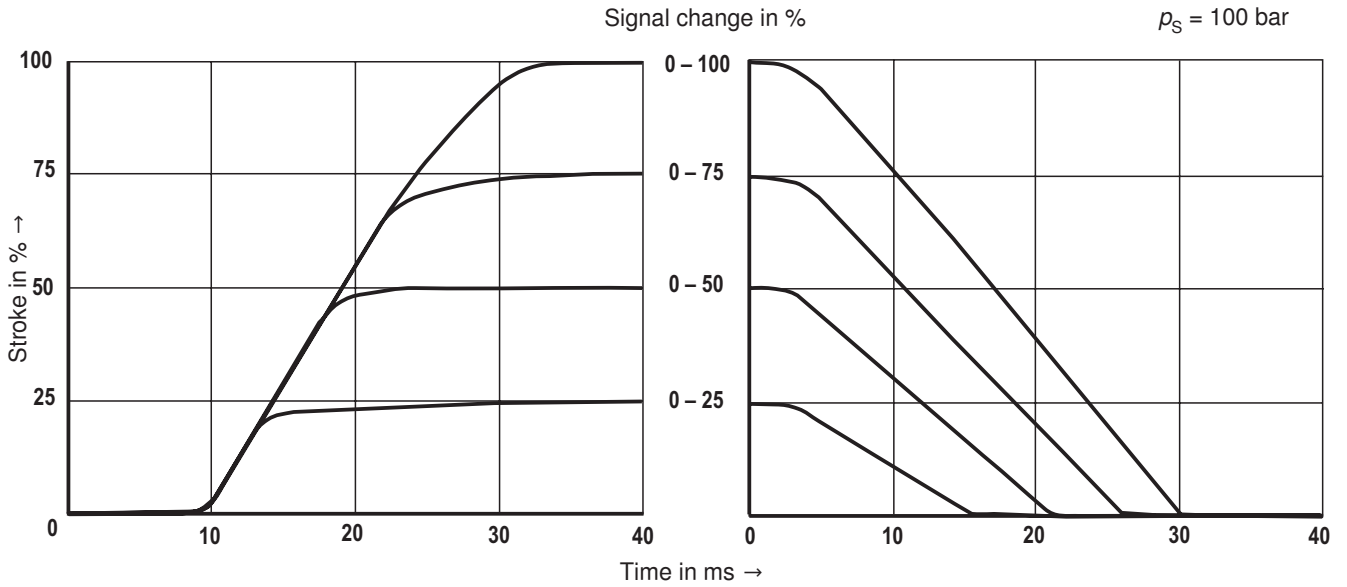

Flow/load function with maximum valve opening

(tolerance $\pm 10\%$)

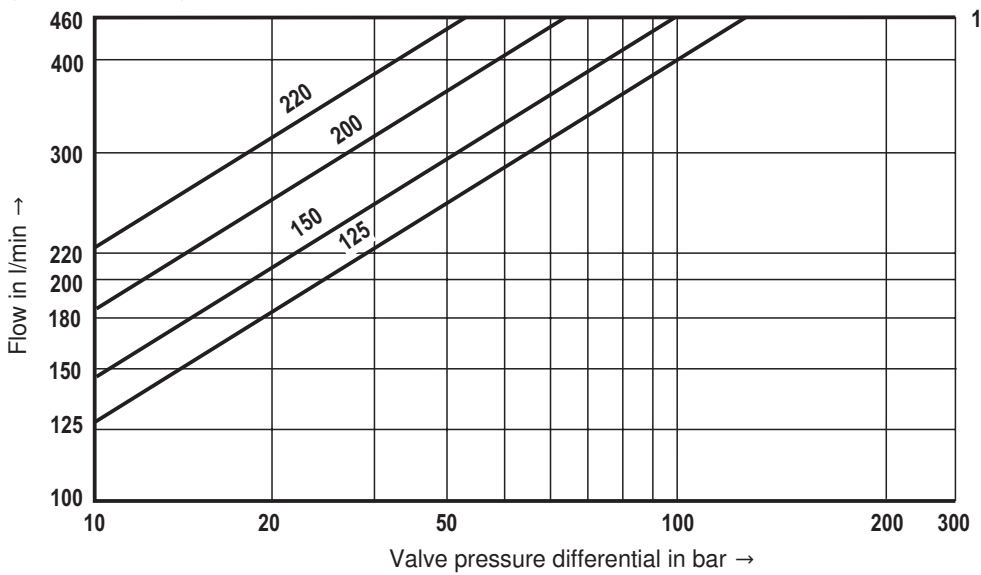

1 = Recommended flow limitation (flow velocity 30 m/s) in the valve connection bores

Characteristic curves: Size 25 and 27 (measured with HLP46, $\dot{v}_{oil} = 40 \text{ }^\circ\text{C} \pm 5 \text{ }^\circ\text{C}$)

Transition function with stepped electric input signals

Measured with $p_S = 100 \text{ bar}$

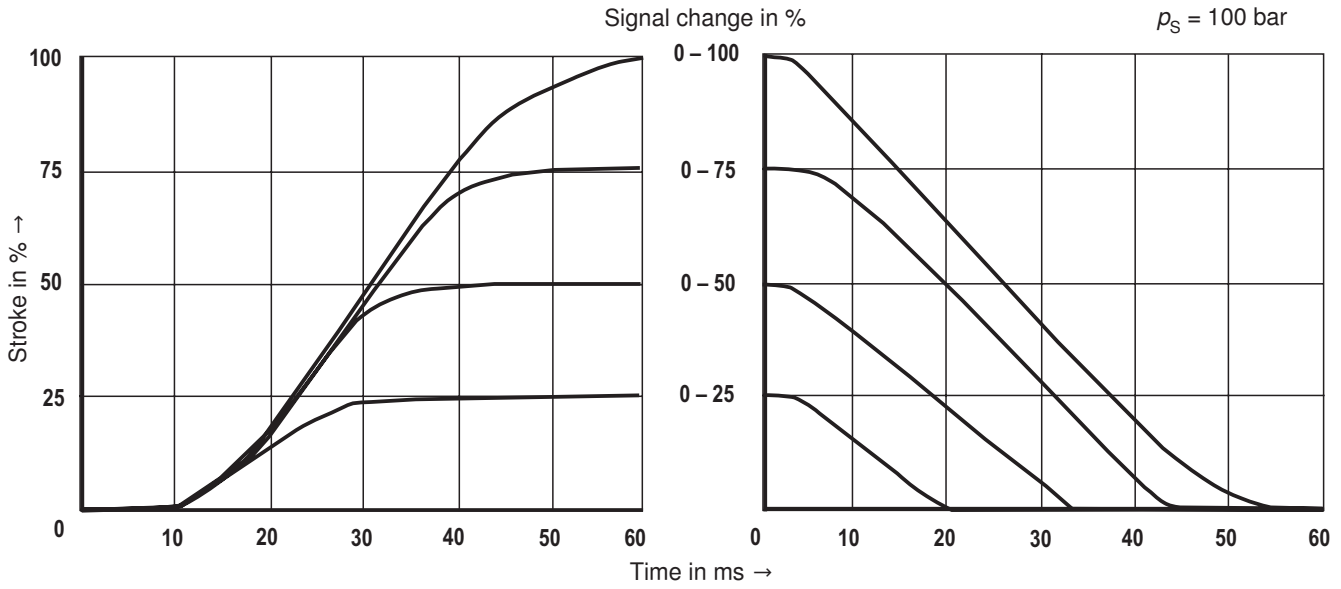

Flow/load function with maximum valve opening
(tolerance $\pm 10\%$)

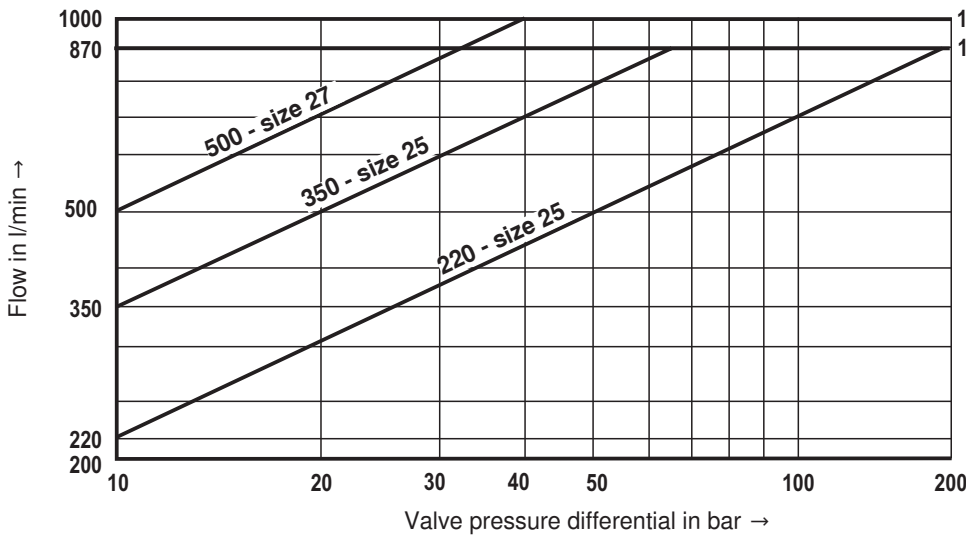

1 = Recommended flow limitation (flow velocity 30 m/s) in the valve connection bores

Characteristic curves: Size 32 (measured with HLP46, $\vartheta_{oil} = 40 \text{ }^\circ\text{C} \pm 5 \text{ }^\circ\text{C}$)

Transition function with stepped electric input signals

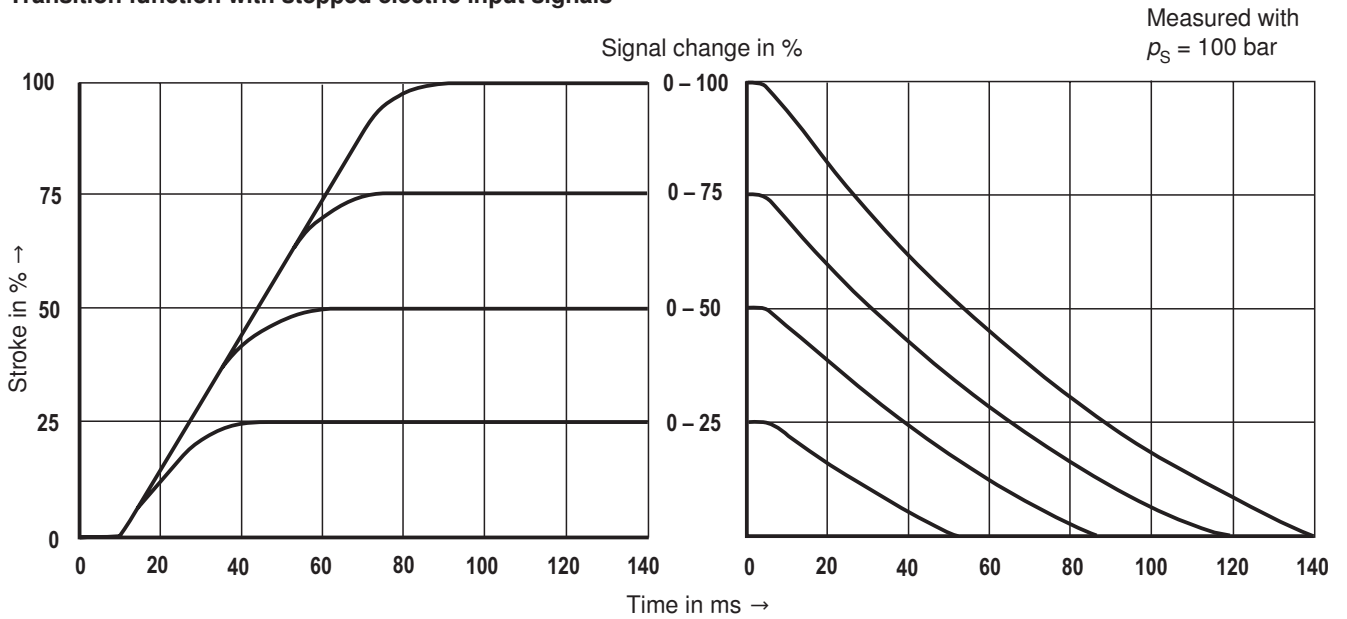

Flow/load function with maximum valve opening
(tolerance $\pm 10\%$)

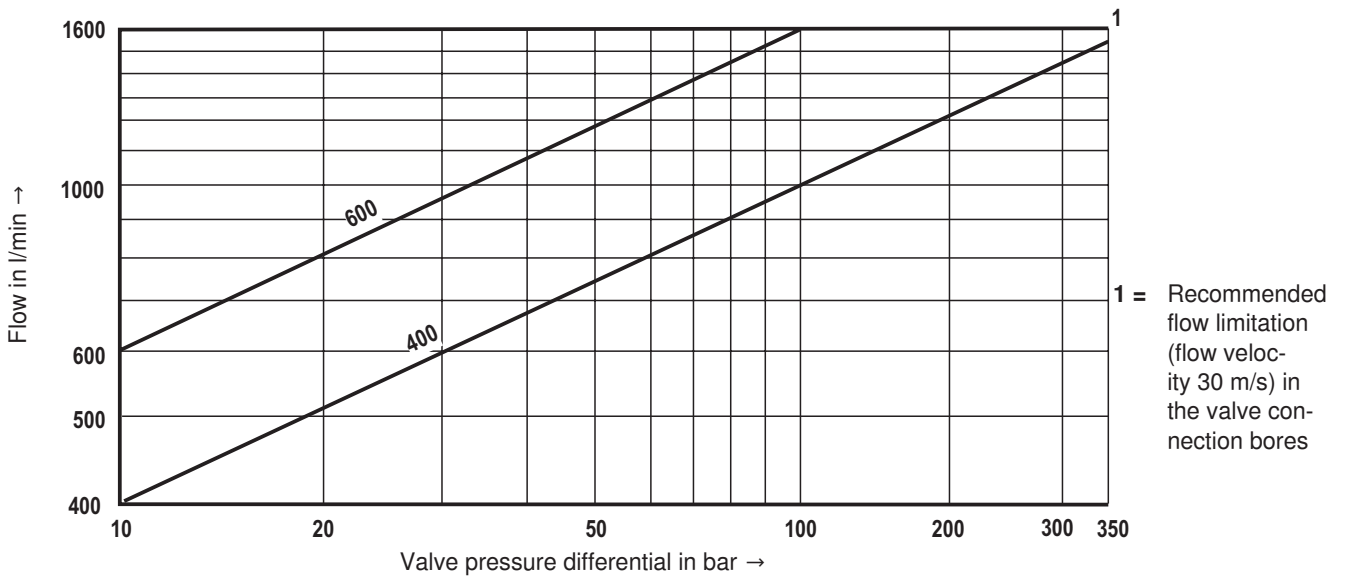

Characteristic curves: Size 35 (measured with HLP46, $\vartheta_{oil} = 40 \text{ }^\circ\text{C} \pm 5 \text{ }^\circ\text{C}$)

Transition function with stepped electric input signals

Measured with $p_s = 100 \text{ bar}$

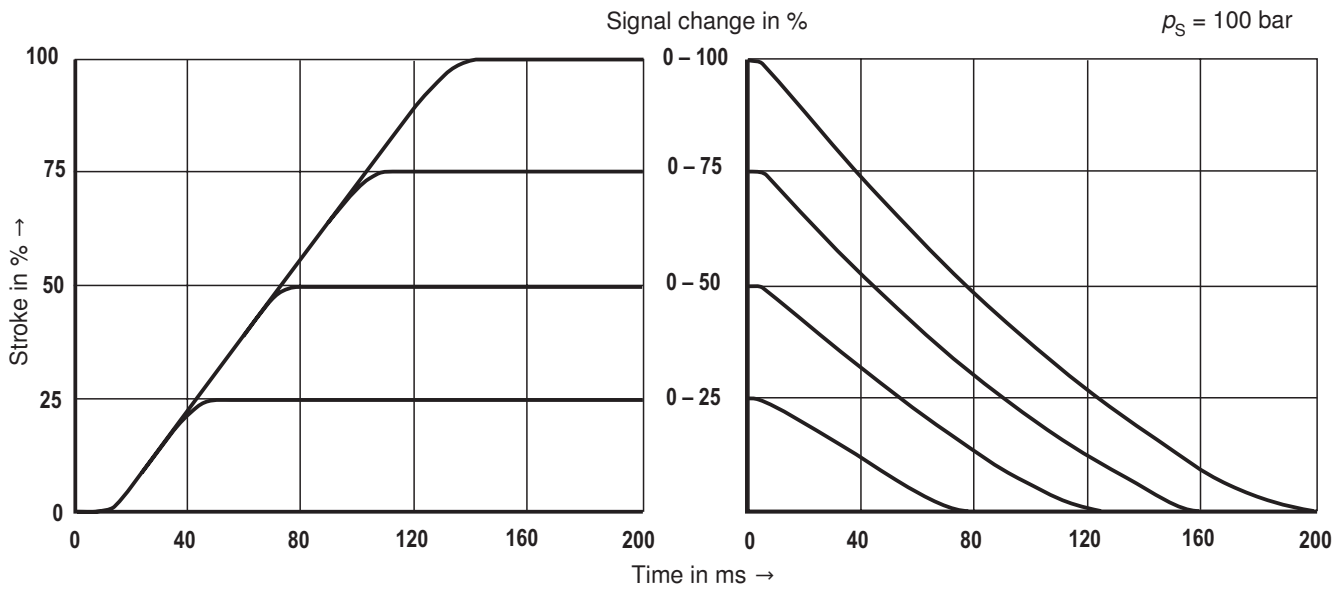

Flow/load function with maximum valve opening
(tolerance $\pm 10\%$)

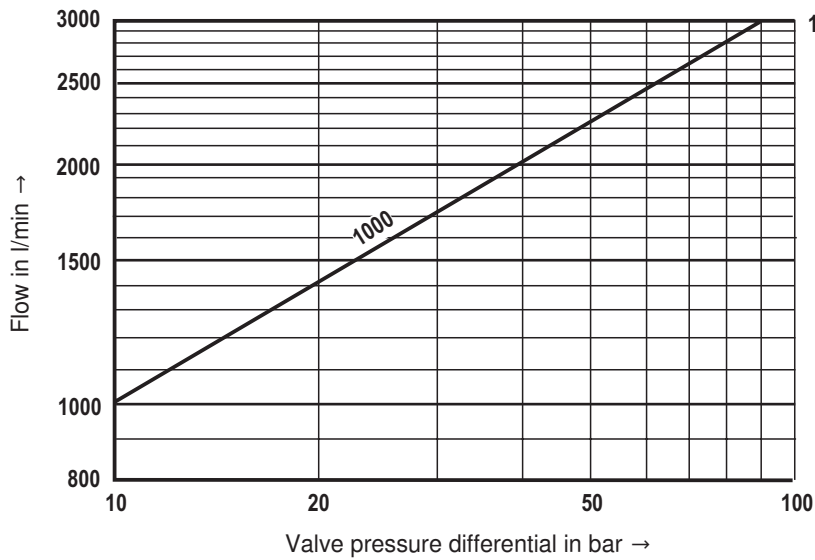

1 = Recommended flow limitation (flow velocity 30 m/s) in the valve connection bores

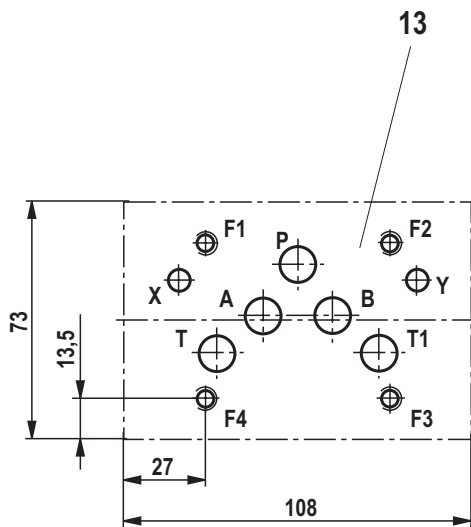
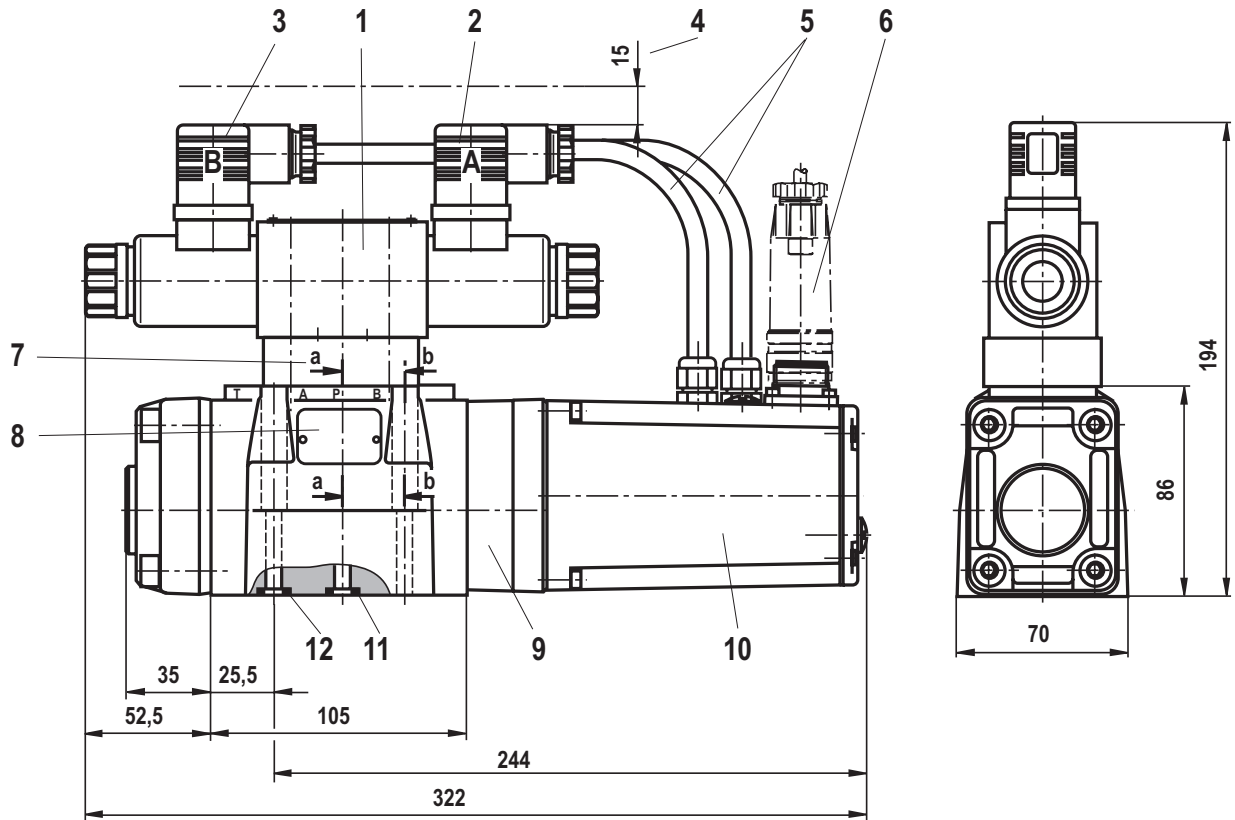
Dimensions: Size 10 (dimensions in mm)

0,01/100
 Rzmax 4
 Required surface quality of the valve contact surface

- | | |
|--|--|
| <ul style="list-style-type: none"> 1 Pilot control valve 2 Mating connector "A", color gray 3 Mating connector "B", color black 4 Space required for connection cable and to remove the mating connector 5 Wiring 6 Mating connector, separate order, see page 21 7 Pressure reducing valve 8 Name plate | <ul style="list-style-type: none"> 9 Main valve 10 Integrated electronics (OBE) 11 Identical seal rings for connection A, B, P, T 12 Identical seal rings for connection X, Y 13 Processed valve contact surface, porting pattern according to ISO 4401-05-05-0-05 (connection X, Y, as required) |
|--|--|

Subplates and valve mounting screws see page 21

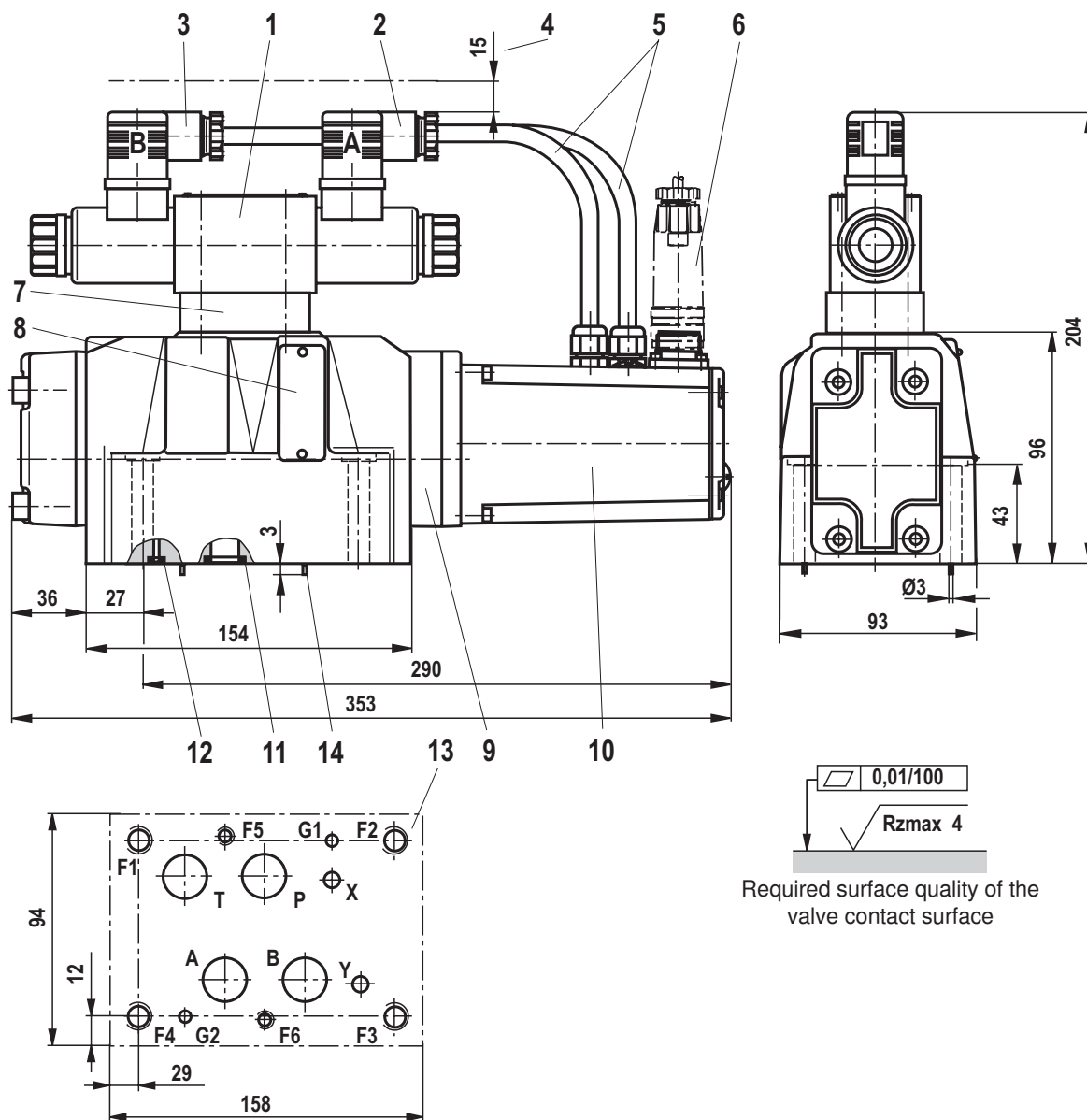
Dimensions: Size 16 (dimensions in mm)

Required surface quality of the valve contact surface

- | | |
|--|--|
| <ul style="list-style-type: none"> 1 Pilot control valve 2 Mating connector "A", color gray 3 Mating connector "B", color black 4 Space required for connection cable and to remove the mating connector 5 Wiring 6 Mating connector, separate order, see page 21 7 Pressure reducing valve 8 Name plate 9 Main valve | <ul style="list-style-type: none"> 10 Integrated electronics (OBE) 11 Identical seal rings for connection A, B, P, T 12 Identical seal rings for connection X, Y 13 Processed valve contact surface, porting pattern according to ISO 4401-07-07-0-05 (connection X, Y as required) deviating from the standard: <ul style="list-style-type: none"> - Connection A, B, T and P \varnothing 20mm 14 Locking pin |
|--|--|

Subplates and valve mounting screws see page 21

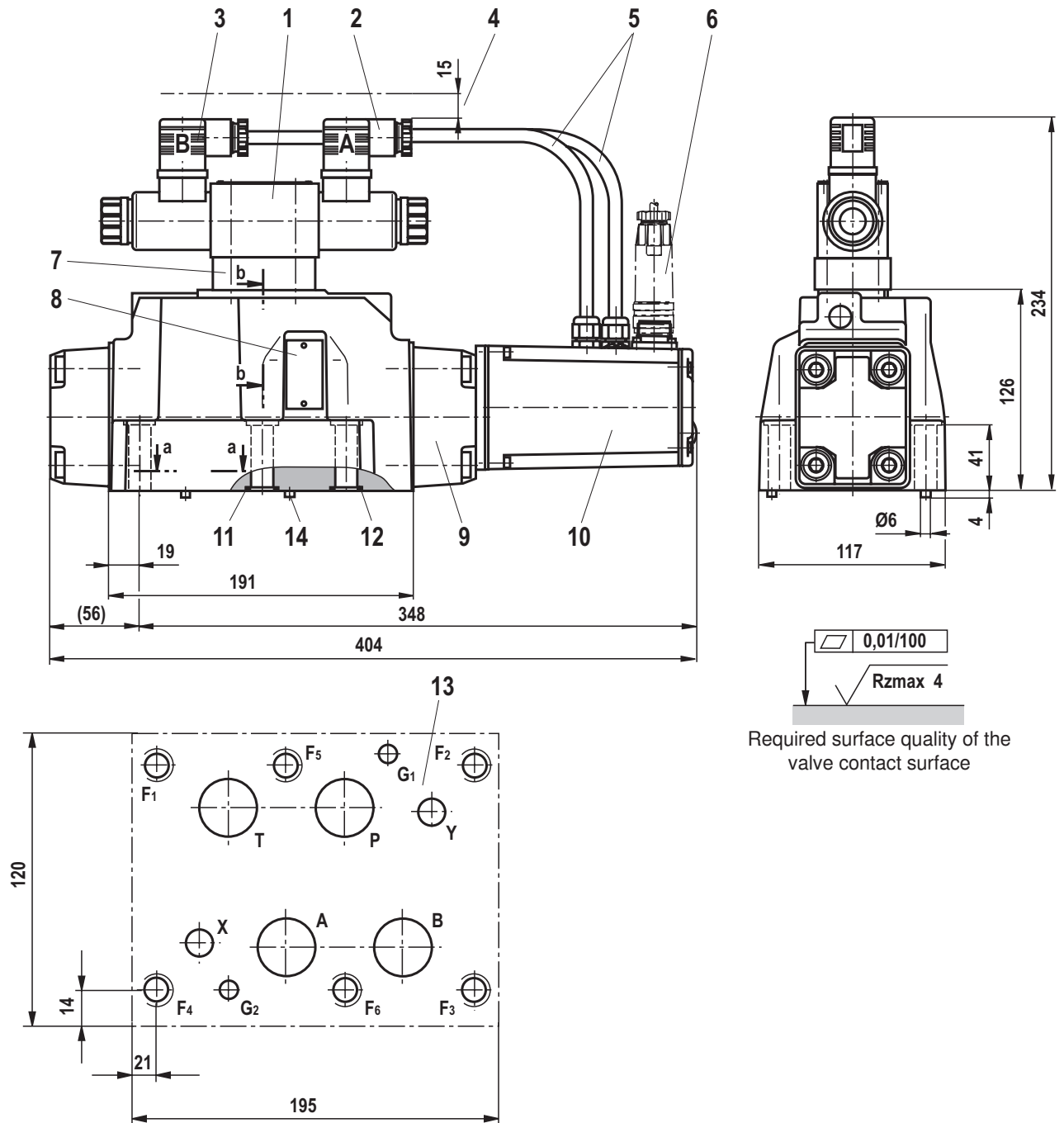
Dimensions: Size 25 (dimensions in mm)

- | | |
|--|--|
| <ul style="list-style-type: none"> 1 Pilot control valve 2 Mating connector "A", color gray 3 Mating connector "B", color black 4 Space required for connection cable and to remove the mating connector 5 Wiring 6 Mating connector, separate order, see page 21 7 Pressure reducing valve 8 Name plate 9 Main valve | <ul style="list-style-type: none"> 10 Integrated electronics (OBE) 11 Identical seal rings for connection A, B, P, T 12 Identical seal rings for connection X, Y 13 Processed valve contact surface, porting pattern according to ISO 4401-08-08-0-05 (connection X, Y, as required) 14 Locking pin |
|--|--|

Subplates and valve mounting screws see page 21

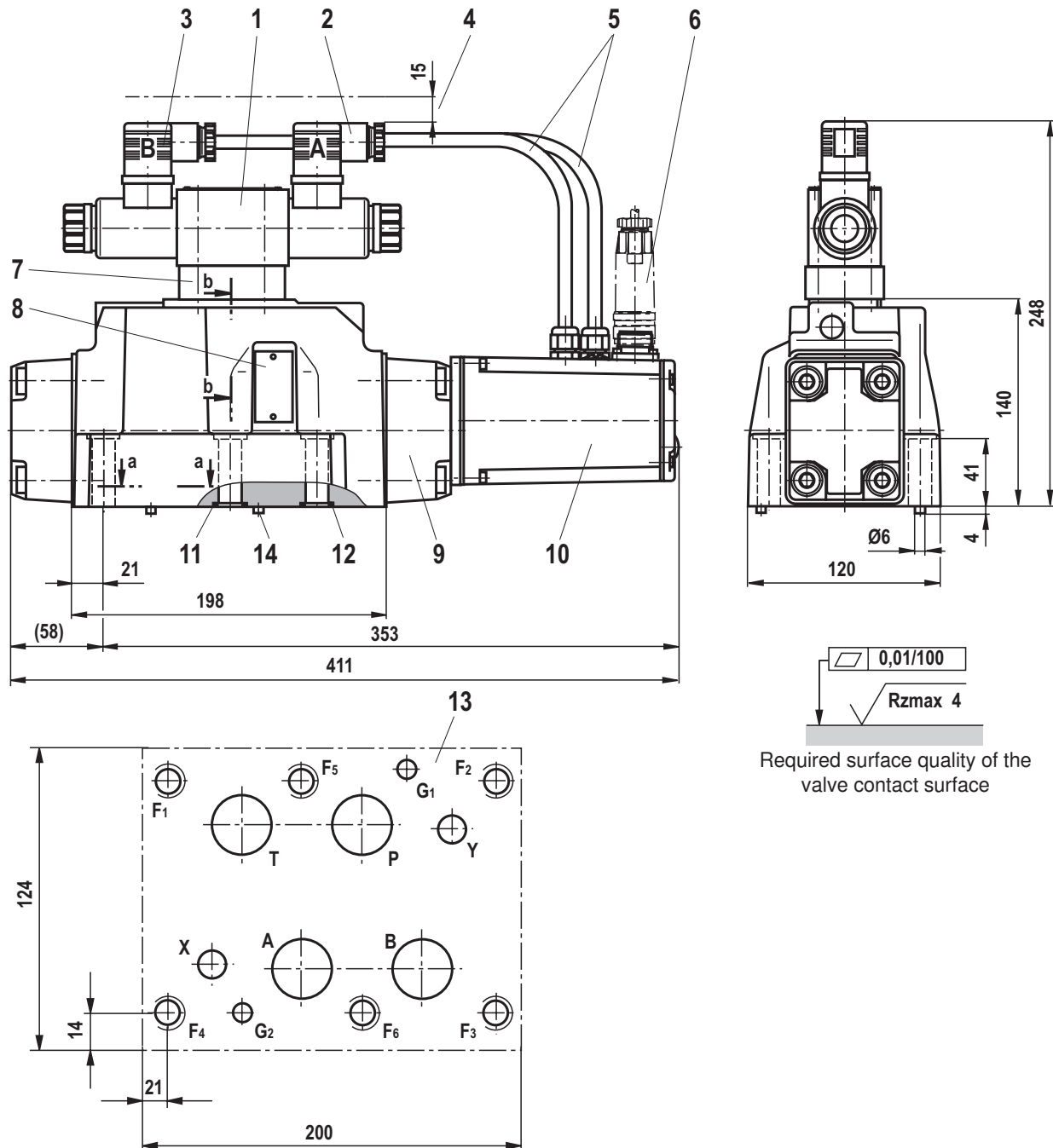
Dimensions: Size 27 (dimensions in mm)

- | | |
|---|---|
| <p>1 Pilot control valve</p> <p>2 Mating connector "A", color gray</p> <p>3 Mating connector "B", color black</p> <p>4 Space required for connection cable and to remove the mating connector</p> <p>5 Wiring</p> <p>6 Mating connector, separate order, see page 21</p> <p>7 Pressure reducing valve</p> <p>8 Name plate</p> <p>9 Main valve</p> | <p>10 Integrated electronics (OBE)</p> <p>11 Identical seal rings for connection A, B, P, T</p> <p>12 Identical seal rings for connection X, Y</p> <p>13 Processed valve contact surface, porting pattern according to ISO 4401-08-08-0-05 (connection X, Y as required) deviating from the standard:
- Connection A, B, T and P \varnothing 32 mm</p> <p>14 Locking pin</p> |
|---|---|

Subplates and valve mounting screws see page 21

Dimensions: Size 32 (dimensions in mm)

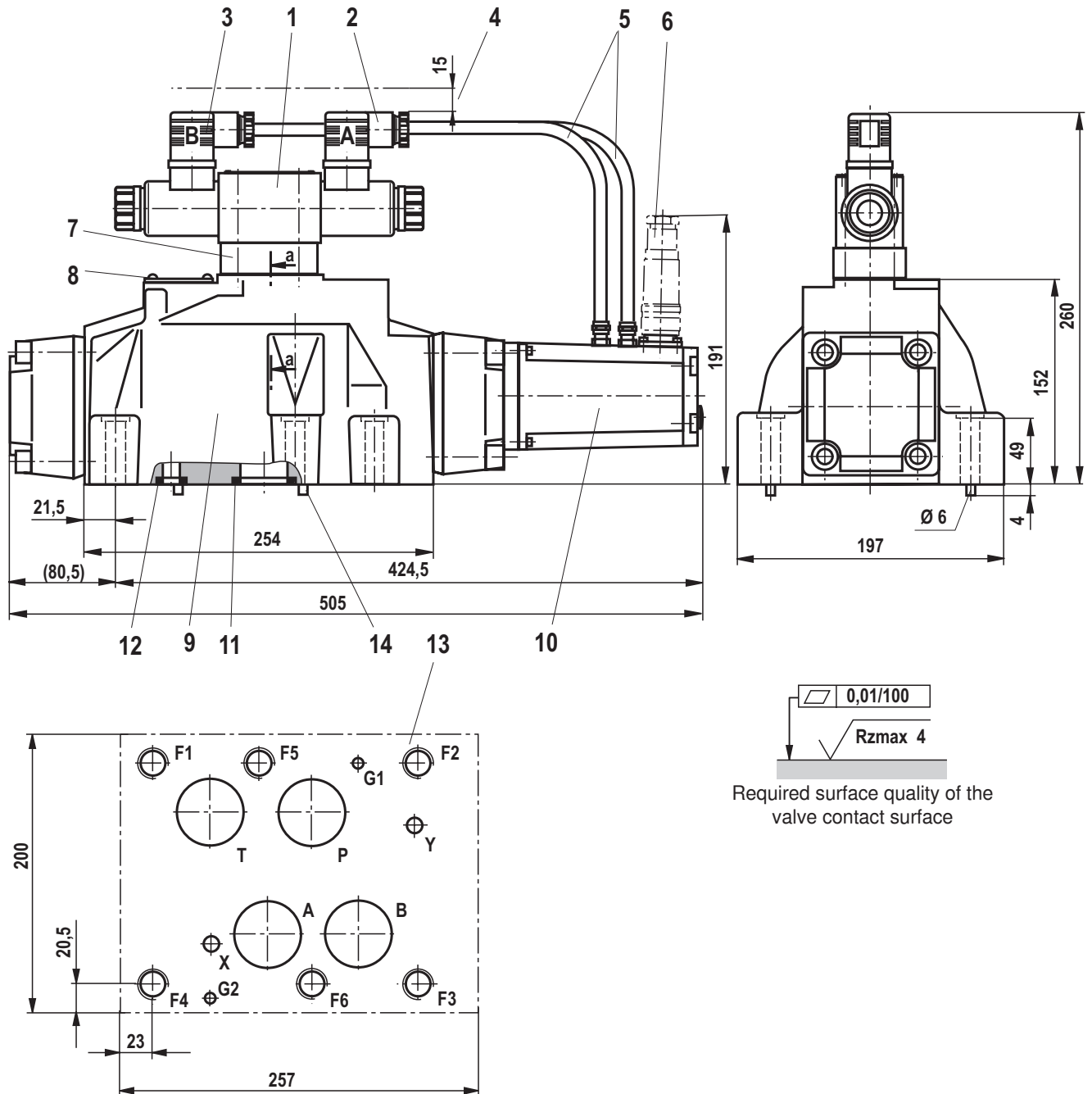

1 Pilot control valve

2 Mating connector "A", color gray

3 Mating connector "B", color black

4 Space required for connection cable and to remove the mating connector

5 Wiring

6 Mating connector, separate order, see page 21

7 Pressure reducing valve

8 Name plate

9 Main valve

10 Integrated electronics (OBE)

11 Identical seal rings for connection A, B, P, T

12 Identical seal rings for connection X, Y

13 Processed valve contact surface, porting pattern according to ISO 4401-10-09-0-05 (connection X, Y as required) deviating from the standard:

- Connection, B, T and P \varnothing 38 mm

14 Locking pin

Required surface quality of the valve contact surface

Subplates and valve mounting screws see page 21

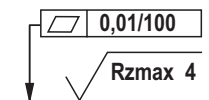
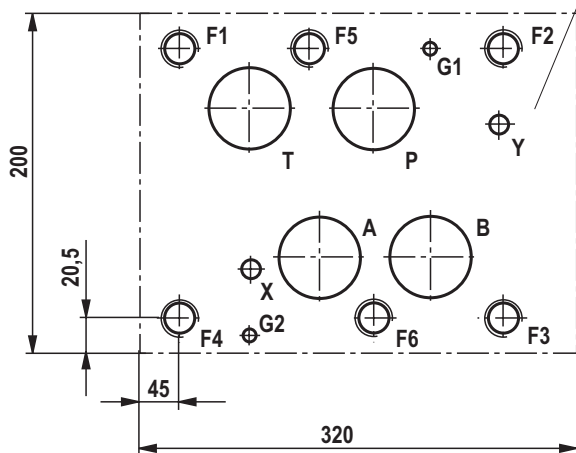
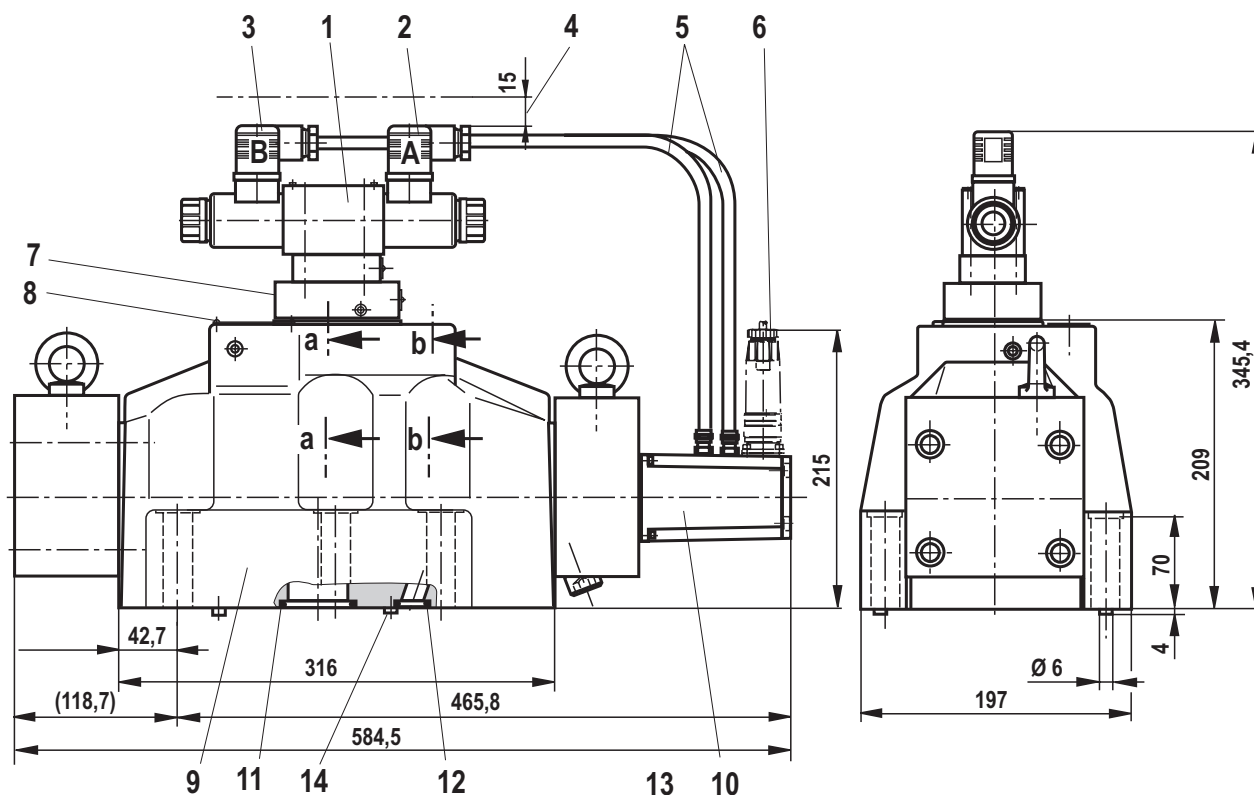
Dimensions: Size 35 (dimensions in mm)

Required surface quality of the valve contact surface

- | | |
|--|---|
| <ul style="list-style-type: none"> 1 Pilot control valve 2 Mating connector "A", color gray 3 Mating connector "B", color black 4 Space required for connection cable and to remove the mating connector 5 Wiring 6 Mating connector, separate order, see page 21 7 Pressure reducing valve 8 Name plate 9 Main valve | <ul style="list-style-type: none"> 10 Integrated electronics (OBE) 11 Identical seal rings for connection A, B, P, T 12 Identical seal rings for connection X, Y 13 Processed valve contact surface, porting pattern according to ISO 4401-10-09-0-05 (connection X, Y as required) deviating from the standard: <ul style="list-style-type: none"> - Connection A, B, T and P \varnothing 50 mm 14 Locating pins |
|--|---|

Subplates and valve mounting screws see page 21

Dimensions

Hexagon socket head cap screws		Material number
Size 10	4x ISO 4762 - M6 x 45 - 10.9-flZn-240h-L Tightening torque $M_A = 13.5 \text{ Nm} \pm 10\%$ or 4x ISO 4762 - M6 x 45 - 10.9 Tightening torque $M_A = 15.5 \text{ Nm} \pm 10\%$	R913000258
Size 16	2x ISO 4762 - M6 x 60 - 10.9-flZn-240h-L Tightening torque $M_A = 12.2 \text{ Nm} \pm 10\%$ 4x ISO 4762 - M10 x 60 - 10.9-flZn-240h-L Tightening torque $M_A = 58 \text{ Nm} \pm 20\%$ or 2x ISO 4762 - M6 x 60 - 10.9 Tightening torque $M_A = 15.5 \text{ Nm} \pm 10\%$ 4x ISO 4762 - M10 x 60 - 10.9 Tightening torque $M_A = 75 \text{ Nm} \pm 20\%$	R913000115 R913000116
Sizes 25 and 27	6x ISO 4762 - M12 x 60 - 10.9-flZn-240h-L Tightening torque $M_A = 100 \text{ Nm} \pm 20\%$ or 6x ISO 4762 - M12 x 60 - 10.9 Tightening torque $M_A = 130 \text{ Nm} \pm 20\%$	R913000121
Size 32	6x ISO 4762 - M20 x 80 - 10.9-flZn-240h-L Tightening torque $M_A = 340 \text{ Nm} \pm 20\%$ or 6x ISO 4762 - M20 x 80 - 10.9 Tightening torque $M_A = 430 \text{ Nm} \pm 20\%$	R901035246
Size 35	6x ISO 4762 - M20 x 100 - 10.9-flZn-240h-L Tightening torque $M_A = 465 \text{ Nm} \pm 20\%$ or 6x ISO 4762 - M20 x 100 - 10.9 Tightening torque $M_A = 610 \text{ Nm} \pm 20\%$	R913000386

Notice: The tightening torque of the hexagon socket head cap screws refers to the maximum operating pressure!

Subplates	Data sheet
Size 10	45054
Size 16	45056
Sizes 25 and 27	45058
Sizes 32 and 35	45060

Accessories (not included in the scope of delivery)

Mating connectors	Material number
Mating connector for high-response valve	DIN EN 175201-804, see data sheet 08006
	e.g. R900021267 (plastic) e.g. R900223890 (metal)

Notes

Notes

Bosch Rexroth AG
Industrial Hydraulics
Zum Eisengießer 1
97816 Lohr am Main, Germany
Phone +49 (0) 93 52 / 18-0
documentation@boschrexroth.de
www.boschrexroth.de

© This document, as well as the data, specifications and other information set forth in it, are the exclusive property of Bosch Rexroth AG. It may not be reproduced or given to third parties without its consent. The data specified above only serve to describe the product. No statements concerning a certain condition or suitability for a certain application can be derived from our information. The information given does not release the user from the obligation of own judgment and verification. It must be remembered that our products are subject to a natural process of wear and aging.

Bosch Rexroth AG
Industrial Hydraulics
Zum Eisengießer 1
97816 Lohr am Main, Germany
Phone +49 (0) 93 52 / 18-0
documentation@boschrexroth.de
www.boschrexroth.de

© This document, as well as the data, specifications and other information set forth in it, are the exclusive property of Bosch Rexroth AG. It may not be reproduced or given to third parties without its consent. The data specified above only serve to describe the product. No statements concerning a certain condition or suitability for a certain application can be derived from our information. The information given does not release the user from the obligation of own judgment and verification. It must be remembered that our products are subject to a natural process of wear and aging.