

**Ordering Code**

**Model No.**

T6DC\* W - B38 - B22 - 1 R 00 - C 1

Series M = Mobile 1 shaft seal

Series P = Mobile 2 shaft seals

Use for severe duty shaft only\*

Cam ring for "P1"

(Delivery at 0 bar & 1500 r.p.m.)

B14 = 71,4 l/min	B35 = 166,5 l/min
B17 = 87,3 l/min	B38 = 180,4 l/min
B20 = 99,0 l/min	B42 = 204,0 l/min
B24 = 119,3 l/min	B45 = 218,5 l/min
B28 = 134,5 l/min	B50 = 237,0 l/min
B31 = 147,4 l/min	

Cam ring for "P2"

(Delivery at 0 bar & 1500 r.p.m.)

B03 = 16,2 l/min	B17 = 87,4 l/min
B05 = 25,8 l/min	B20 = 95,7 l/min
B06 = 31,9 l/min	B22 = 105,4 l/min
B08 = 39,6 l/min	B25 = 118,9 l/min
B10 = 51,1 l/min	B28 = 133,2 l/min
B12 = 55,6 l/min	B31 = 150,0 l/min
B14 = 69,0 l/min	

**Modification**

**Seal Class**

- 1 = S1 (for mineral oil)
- 4 = S4 (for the resistant fluids)
- 5 = S5 (for mineral oil and fire resistant fluids)

**Design letter**

00 = standard

**Direct. of rotation (view on shaft end)**

- R = clockwise
- L = counter-clockwise

**Type of shaft**

- P version
- 3 = splined (no SAE)

**Type of shaft**

- M version
- 1 = keyed (SAE C)
- 2 = keyed (no SAE)
- 3 = splined (SAE C)
- 4 = splined (no SAE)

**MW severe duty**

- \*5 = keyed (no SAE)
- \*T = splined (SAE J718c)

**INTERNAL LEAKAGE (TYPICAL)**

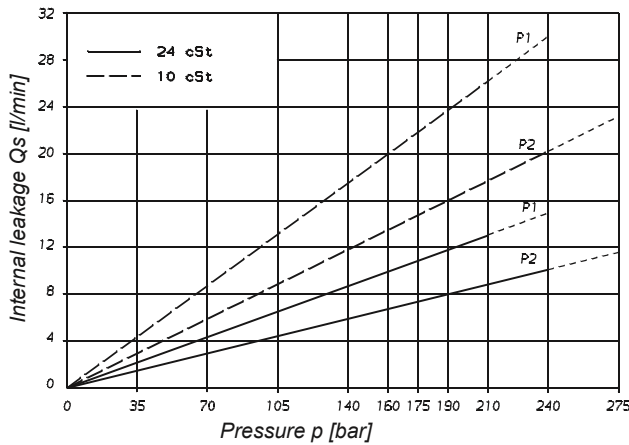

Do not operate the pump more than 5 seconds at any speed or viscosity if internal leakage is more than 50 % of theoretical flow. Total leakage is the sum of each section loss at its operating conditions.

**NOISE LEVEL (TYPICAL)**

T6DCM - B38 - B22

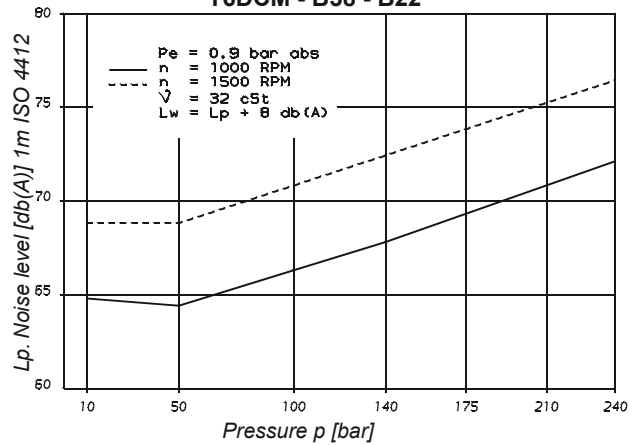

Double pump noise level is given with each section discharging at the pressure noted on the curve.

**POWER LOSS HYDROMECHANICAL (TYPICAL)**

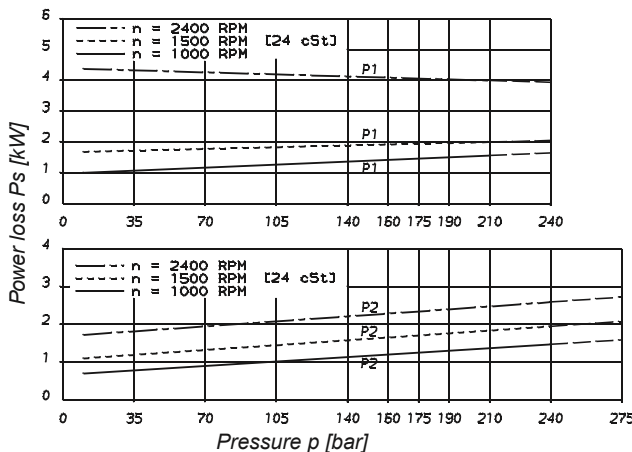

Total hydrodynamic power loss is the sum of each section at its operating conditions.

**PERMISSIBLE RADIAL LOAD**

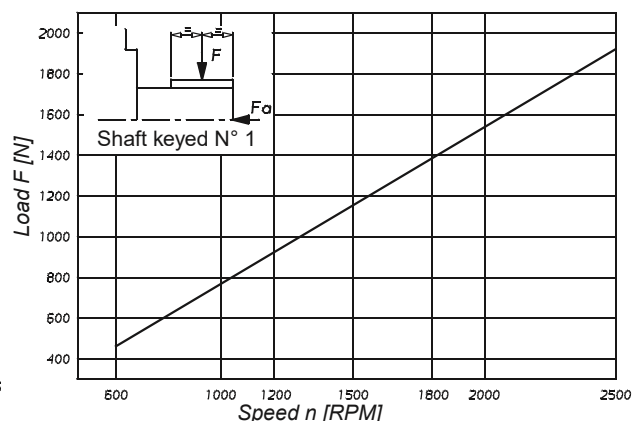

Maximum permissible axial load Fa = 1200 N

Dimensions and Characteristics

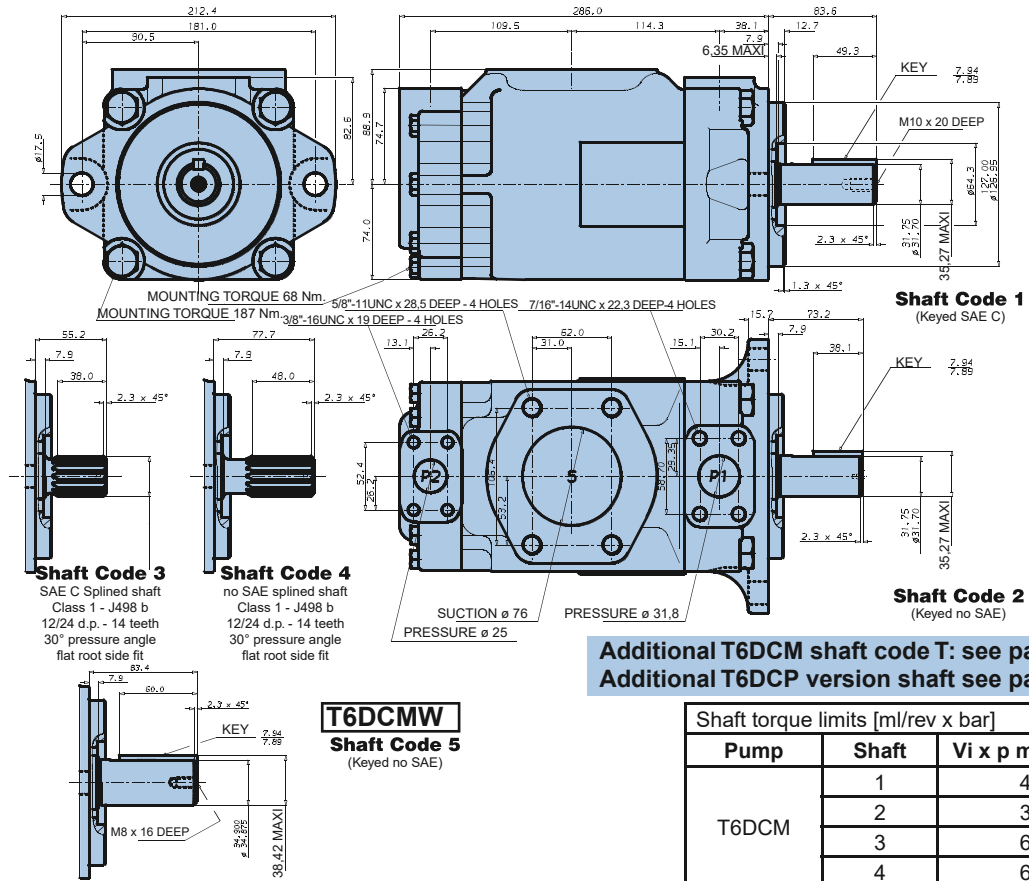

Shaft torque limits [ml/rev x bar]		
Pump	Shaft	Vi x p max. P1 + P2
T6DCM	1	43240
	2	34590
	3	61200
	4	61200
T6DCMW	5	55600

OPERATING CHARACTERISTICS - TYPICAL [24 cSt]

Pressure port	Series	Volumetric Displacement Vi	Flow Q [l/min] & n = 1500 RPM			Input power P [kW] & n = 1500 RPM		
			p = 0 bar	p = 140 bar	p = 240 bar	p = 7 bar	p = 140 bar	p = 240 bar
P1	B14	47,6 ml/rev	71,4	62,1	55,9	2,3	18,5	30,6
	B17	58,2 ml/rev	87,3	78,0	71,8	2,5	22,2	37,0
	B20	66,0 ml/rev	99,0	89,7	83,5	2,8	24,9	41,7
	B24	79,5 ml/rev	119,3	110,0	103,8	3,0	29,6	49,8
	B28	89,7 ml/rev	134,5	125,2	119,0	3,2	33,2	55,9
	B31	98,3 ml/rev	147,4	138,1	131,9	3,3	36,2	61,0
	B35	111,0 ml/rev	166,5	157,2	151,0	3,5	40,7	68,7
	B38	120,3 ml/rev	180,4	171,1	164,9	3,7	43,9	74,3
	B42 <sup>2)</sup>	136,0 ml/rev	204,0	194,7	188,5	4,0	49,4	83,7
	B45 <sup>2)</sup>	145,7 ml/rev	218,5	209,2	203,0	4,1	52,8	89,5
B50 <sup>2)</sup>	158,0 ml/rev	237,0	227,7	224,0 <sup>1)</sup>	4,4	57,0	85,0 <sup>1)</sup>	
P2	B03	10,8 ml/rev	16,2	10,7	-	1,3	5,3	-
	B05	17,2 ml/rev	25,8	20,3	15,8	1,4	7,5	12,2
	B06	21,3 ml/rev	31,9	26,5	22,0	1,5	8,9	14,7
	B08	26,4 ml/rev	39,6	34,1	29,6	1,6	10,7	17,7
	B10	34,1 ml/rev	51,1	45,7	41,2	1,7	13,4	22,3
	B12	37,1 ml/rev	55,6	50,2	45,7	1,7	14,4	24,1
	B14	46,0 ml/rev	69,0	63,5	59,0	1,9	17,6	29,5
	B17	58,3 ml/rev	87,4	82,0	77,5	2,1	21,9	36,9
	B20	63,8 ml/rev	95,7	90,2	85,7	2,2	23,8	40,2
	B22	70,3 ml/rev	105,4	100,0	95,5	2,3	26,1	44,1
	B25	79,3 ml/rev	118,9	113,5	109,0	2,5	29,2	49,5
	B28	88,8 ml/rev	133,2	127,7	124,5 <sup>1)</sup>	2,8	32,7	48,5 <sup>1)</sup>
	B31	100,0 ml/rev	150,0	144,5	141,3 <sup>1)</sup>	2,8	36,5	54,4 <sup>1)</sup>

<sup>1)</sup> B28 - B31 - B50 = 210 bar max. int.    <sup>2)</sup> B42 - B45 - B50 = 2200 R.P.M. max

- Not to use because internal leakage greater than 50% theoretical flow

Port connection can be furnished with metric threads.