

Model No. **T6CC W - 022 - 008 - 1 R 00 - C 1 00 - ..**

Series - SAE B 2 bolts **J744 mounting flange** **P1** **P2**

Severe duty shaft option

Displacement P1 and P2

Volumetric displacement (ml/rev.)

003 = 10,8 017 = 58,3
 005 = 17,2 020 = 63,8
 006 = 21,3 022 = 70,3
 008 = 26,4 025 = 79,3
 010 = 34,1 028 = 88,8
 012 = 37,1 031 = 100,0
 014 = 46,0

Type of shaft **Severe duty shaft (T6CCW only)**

1 = keyed (non SAE) 2 = keyed (SAE BB)
 3 = splined (SAE BB) 15 teeth
 5 = splined (SAE B) 13 teeth

Direction of rotation (shaft end view)

R = Clockwise
 L = Counter-clockwise

Modifications

Mounting w/connection variables

	P1 = 1" - S = 3"			
	UNC thread		Metric thread	
	00	01	0M	W0
P2	1"	3/4" ¹⁾	1"	3/4"

	P1 = 1" - S = 2.1/2" ²⁾			
	UNC thread		Metric thread	
	10	11	1M	W1
P2	1"	3/4" ¹⁾	1"	3/4"

¹⁾ up to 46 ml/rev. max.

²⁾ up to 126 ml/rev. max.

Always select the largest cartridge in the front place.

Seal class

1 = S1 BUNA N - 0,7 bar max. (for mineral oil)
 4 = S4 EPDM - 7 bar max. (for fire resistant fluids)
 5 = S5 VITON® - 7 bar max. (for mineral oil and fire resistant fluids)

Design letter

Porting combination (see page 72)

00 = standard

INTERNAL LEAKAGE (TYPICAL)

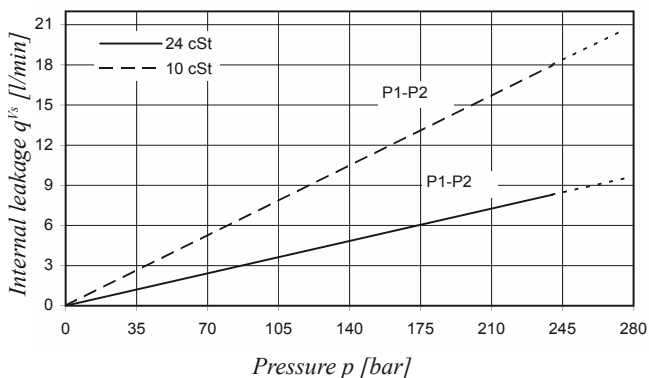

Do not operate pump more than 5 seconds at any speed or viscosity if internal leakage is higher than 50% of theoretical flow.

Total leakage is the sum of each section loss under its respective operating conditions.

POWER LOSS HYDROMECHANICAL (TYPICAL)

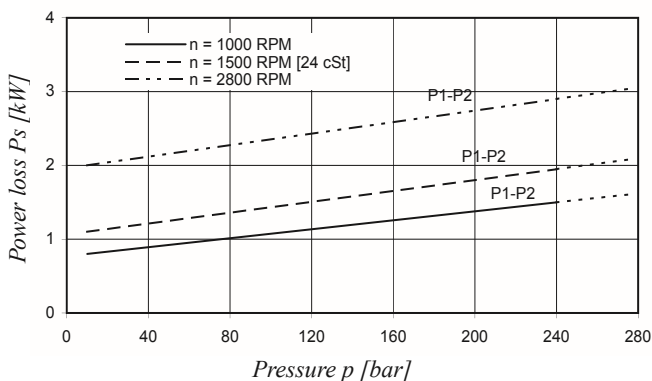

Total hydromechanical power loss is the sum of each section loss under its respective operating conditions.

NOISE LEVEL (TYPICAL) - T6CC - 022 - 022

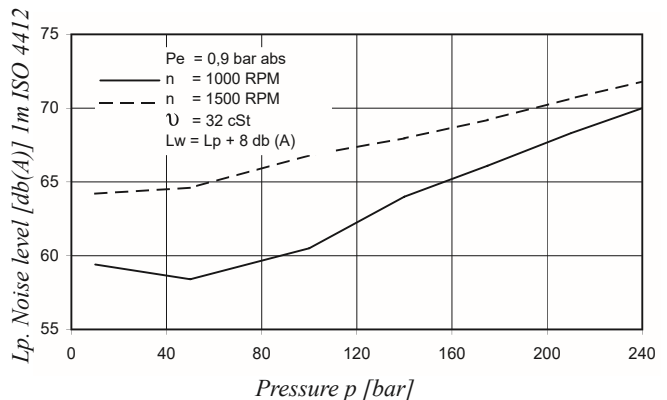

Double pump noise level is given with both stages discharging at the pressure value indicated on the curve.

PERMISSIBLE RADIAL LOAD

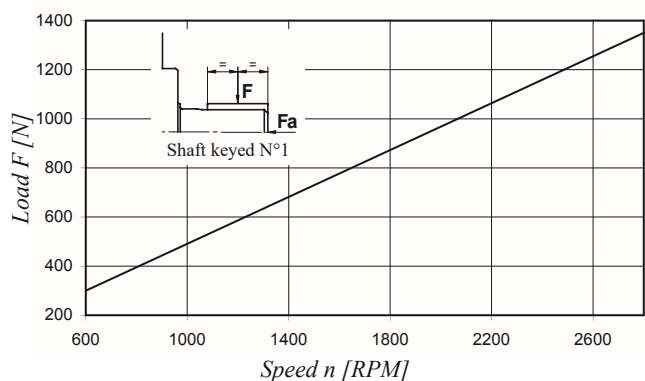

Maximum permissible axial load Fa = 800 N

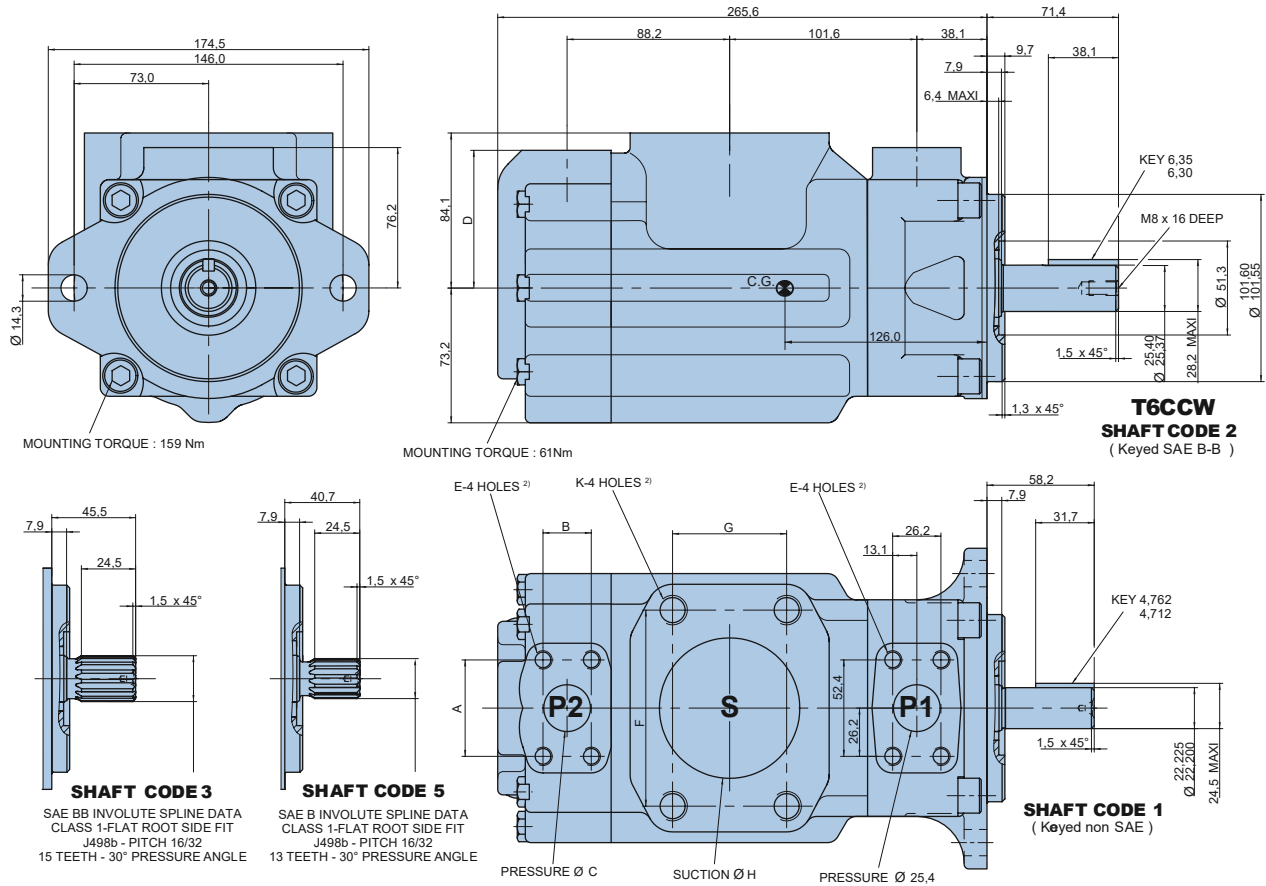

Alternate ports								
Code	S = 3"				S = 2.1/2"²)			
	00	01 ¹⁾	0M	W0 ¹⁾	10	11 ¹⁾	1M	W1 ¹⁾
A	52,4	47,7	52,4	47,7	52,4	47,7	52,4	47,7
B	26,2	22,4	26,2	22,4	26,2	22,4	26,2	22,4
Ø C	25,4	19,0	25,4	19,0	25,4	19,0	25,4	19,0
D	74,7	76,2	74,7	76,2	74,7	76,2	74,7	76,2
E	3/8"-16 UNC x 19 deep		M10 x 19 deep		3/8"-16 UNC x 19 deep		M10 x 19 deep	
F	106,4				88,9			
G	61,9				50,9			
Ø H	76,2				63,5			
K	5/8"-11UNC x 28,4 deep		M16 x 28,4 deep		1/2"-13 UNC x 23,9 deep		M12 x 23,9 deep	

Shaft torque limits [ml/rev. x bar]	
Shaft	Vi x p max.
1	14300
2	21420
3	32670
5	20600

¹⁾ Max. cam 014 ²⁾ P1 + P2 = 126 ml/rev. max.

OPERATING CHARACTERISTICS - TYPICAL [24 cSt]

Pressure port	Series	Vi Volumetric displacement	Flow q _v [l/min] & n = 1500 RPM			Input power P [kW] & n = 1500 RPM		
			p = 0 bar	p = 140 bar	p = 240 bar	p = 7 bar	p = 140 bar	p = 240 bar
P1 & P2	003	10,8 ml/rev	16,2	11,2	7,7	1,3	5,3	8,4
	005	17,2 ml/rev	25,8	20,8	17,3	1,4	7,5	12,2
	006	21,3 ml/rev	31,9	26,9	23,4	1,5	8,9	14,7
	008	26,4 ml/rev	39,6	34,6	31,1	1,6	10,7	17,7
	010	34,1 ml/rev	51,1	46,1	42,6	1,7	13,4	22,3
	012	37,1 ml/rev	55,6	50,6	47,1	1,7	14,4	24,1
	014	46,0 ml/rev	69,0	64,0	60,5	1,9	17,6	29,5
	017	58,3 ml/rev	87,4	82,4	78,9	2,1	21,9	36,9
	020	63,8 ml/rev	95,7	90,7	87,2	2,2	23,8	40,2
	022	70,3 ml/rev	105,4	100,4	96,9	2,3	26,1	44,1
	025	79,3 ml/rev	118,9	113,9	110,4	2,5	29,2	49,5
	028	88,8 ml/rev	133,2	128,2	125,8 ¹⁾	2,8	32,7	48,5 ¹⁾
	031	100,0 ml/rev	150,0	145,0	142,6 ¹⁾	2,8	36,5	54,4 ¹⁾

¹⁾ 028 - 031 = 210 bar max. int. ²⁾ Port connection can be supplied with metric threads, please contact Parker.

